

DESCRIPTION

- Produces a hollow cone spray pattern using an external pintle deflector.
- Relatively uniform distribution at low pressures.
- Produces coarser droplets than a normal hollow-cone spray.
- Standard spray angle is 164° but is available with other spray angles.
- The pintle deflector is spring loaded and will “pop-up” under pressure to produce the spray pattern. When the pressure reduces the pintle returns to its seat to prevent ingress from the external process.
- Manufactured with a 3/4” male thread
- Made Stainless Steel 316



TECHNICAL DATA

TYPE	Flow rate (lpm) @ pressure (Bar)							
	0,7	1,0	2,0	3,0	4,0	5,0	6,0	7,0
3/4” PU 50	9,61	11,61	16,07	19,89	22,77	25,50	27,93	30,19
3/4” PU 60	11,44	13,84	19,20	23,67	27,23	30,69	33,61	36,14
3/4” PU 70	13,27	16,07	22,77	27,46	32,14	35,88	39,30	42,54
3/4” PU 80	15,10	18,75	25,45	31,72	36,61	41,06	44,98	48,03
3/4” PU 90	16,73	20,00	28,95	35,10	40,95	45,02	50,01	54,00
3/4” PU 100	19,21	22,77	31,70	39,30	45,53	51,00	55,87	60,38
3/4” PU 125	24,01	28,46	39,62	49,12	56,91	63,75	69,83	75,48
3/4” PU 150	28,6	34,2	48,4	59,3	68,4	76,5	83,8	90,5

Maximum Recommended Pressure: 14 Bar.G.

DIMENSIONS

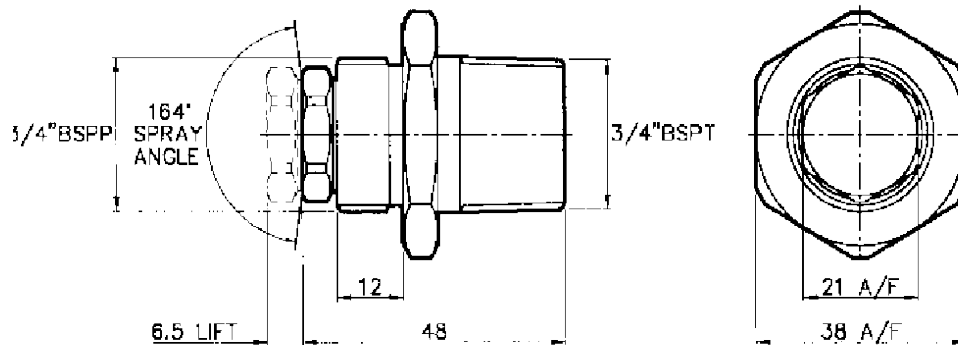

HOW TO ORDER

3/4” PU type
3/4” PU 150