

DESCRIPTION

The CIP15 is used in place of a standard full cone nozzle where finer atomization than a single nozzle might normally provide is required. The nozzle body is fitted with 15 removable solid cone spray nozzles. The CIP15 provides relatively uniform distribution at all pressures and a normal spray angle of 230°. For full 360° coverage with type CIP15, the assembly is identified with the suffix 'FC'

- Available in a range of flow rates
- Manufactured with a 1 1/2" BSPT Female threaded body
- Different spray nozzles can be installed to give non-standard spray patterns for targeted cleaning
- Made in Brass and Stainless Steel as standard
- Other materials available to special order

**TECHNICAL DATA**

TYPE	Nozzles	Flow rate (lpm) @ pressure (Bar)								Approx. Diameter of Coverage (mm)		
		0,7	1,0	2,0	3,0	4,0	5,0	6,0	7,0	@Bar		
										1,0	3,0	5,0
1.1/2" CIP 15 -100	1/4" BIM 6	18,75	22,50	28,20	32,70	39,75	44,44	51,15	53,10	900	1600	1900
1.1/2" CIP 15 -140	1/4" BIM 8	27,90	34,20	42,60	48,15	60,00	67,08	80,70	85,80	900	1600	1900
1.1/2" CIP 15 -200	1/4" BIM 12	41,85	51,15	61,35	68,25	79,95	89,39	105,30	113,70	900	1600	1900
1.1/2" CIP 15 -275	3/8" BIM 16	53,70	66,15	79,50	92,10	109,05	121,92	142,65	150,60	1050	1900	2250
1.1/2" CIP 15 -350	3/8" BIM 20	66,90	81,90	97,50	113,10	135,90	151,94	178,80	189,45	1050	1900	2250
1.1/2" CIP 15 -380	3/8" BIM 22	76,65	93,60	112,65	124,80	146,70	164,02	198,45	213,60	1050	1900	2250
1.1/2" CIP 15 -470	3/8" BIM 27	90,60	111,30	135,15	151,50	184,80	206,61	240,90	262,05	1400	2500	2950
1.1/2" CIP 15 -550	3/8" BIM 32	108,75	133,20	162,15	184,80	216,60	242,17	289,35	306,00	1400	2500	2950
1.1/2" CIP 15 -100 FC	1/4" BNM 6	18,75	22,50	32,70	39,75	43,05	48,13	51,15	53,10	800	1550	1750
1.1/2" CIP 15 -140 FC	1/4" BNM 8	27,90	34,20	48,45	60,00	68,25	76,31	80,70	85,80	800	1550	1750
1.1/2" CIP 15 -190 FC	1/4" BNM 11	41,85	48,45	64,65	77,25	81,75	91,40	100,95	111,45	800	1550	1750
1.1/2" CIP 15 -250 FC	1/4" BNM 15	55,05	67,50	83,85	99,60	108,60	121,42	130,50	137,40	1000	1850	2100
1.1/2" CIP 15 -300 FC	1/4" BNM 18	66,00	80,85	100,50	119,40	130,20	145,57	156,45	164,70	1000	1850	2100
1.1/2" CIP 15 -380 FC	3/8" BNM 22	83,70	102,60	127,50	151,50	165,15	184,64	198,45	209,10	1000	1850	2100
1.1/2" CIP 15 -430 FC	3/8" BNM 25	90,60	108,60	139,80	165,15	184,80	206,61	219,75	236,40	1200	2250	2600
1.1/2" CIP 15 -550 FC	3/8" BNM 32	115,50	137,25	178,80	214,50	236,70	264,64	283,50	298,50	1200	2250	2600

Maximum Recommended Pressure: 35 Bar.G.

DIMENSIONS

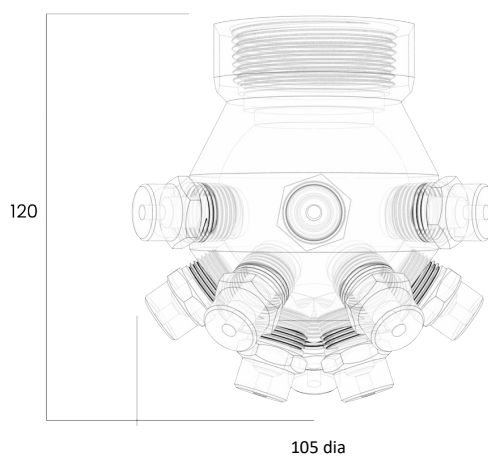

HOW TO ORDER

1 1/2" CIP 15- type
1 1/2" CIP 15 -380 FC